

Rapid Response Water Reuse System

- RRWRS -

*Recovers for Reuse 10,000 Gallons/Day of Potable Quality Water
from 12,000 Gallons/Day of Shower and Laundry Waste Water*

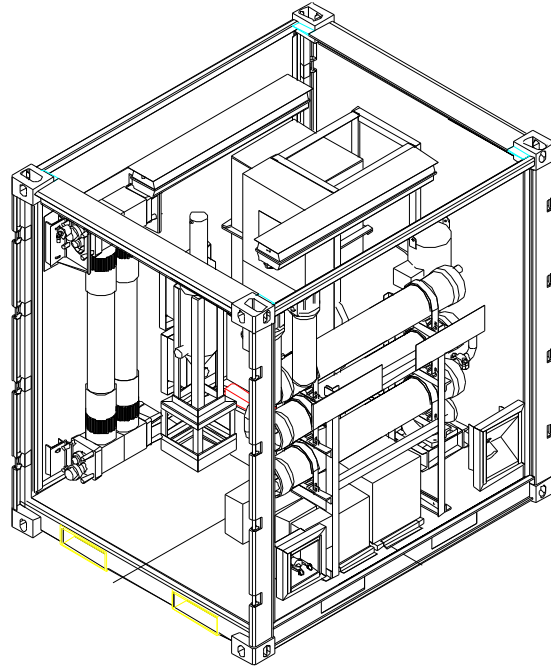

The Outdoor Venture RRWRS is a rapidly deployable gray wastewater (used shower and laundry water) reuse system, capable of saving up to 10,000 GPD of potable water demand. The key missions served are emergency response and disaster relief camps with broad use potential.

- | | |
|---|---|
| <ul style="list-style-type: none">• Reduces need for potable water production and distribution assets. Reduces fuel demand and transportation exposure.• PLC and Touch Screen control provides simple operation with minimal training.• Supports unattended operation with PMCS and operator services at seven day intervals. | <ul style="list-style-type: none">• Fully automatic after startup. Stops to Standby upon low wastewater tank level. Resumes treating upon increased level.• Fully tested and water quality certified for human consumption for treated gray wastewater.• Fully integrated and self-contained system. Provides rapid deployment and setup. |
|---|---|



Engineered Solutions LLC

2740 South Highway 1651

Stearns, KY 42647-6209

606-376-5021 www.outdoorventure.com

Key Components

- Diverter automatically diverts wastewater
- Automatically cleaned stainless steel screen filter removes hair and debris
- Automatically backwashed Micro-Filter removes dirt, blood and bacteria
 - Automatically chlorine sanitized during system Standby
- Seawater reverse osmosis elements remove salts and organic materials and provide a second barrier to bacteria
 - Alarm and shutdown if RO product water quality is out of specification
- Carbon filters remove any taste and odor

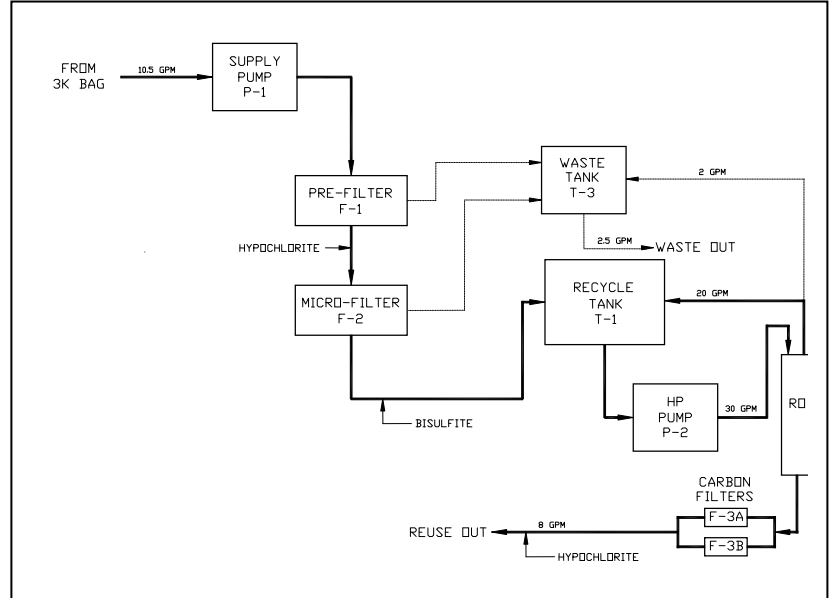

Controls and Instrumentation

- Automatic valves
- Startup BIT to verify valve operation and instrumentation
- PLC control and touch screen operator interface
 - Leads operator through startup and short term and long term shutdown steps
 - Step execution and RO flow control are automatic
 - Screens show flow diagrams with pressures, flows and other information
 - Alarm screen identifies faults
- Conductivity instrument monitors wastewater and reuse conductivity. PLC comparison verifies RO performance
- Flow and pressure instruments provide feedback to PLC for automatic operation
- Automatic variable speed ventilation fan
- Automatic ceiling mounted heater

Equipment Data

- Fully self contained and ready for deployment within Type II Tricon
- 7,100 lb fully packed out for deployment
- 3,000 gallon wastewater tank provided
- 50 foot power cable provided
- 208-Volt, 3 phase, 50 or 60 Hz power
- 20 kW maximum normal operation
- 29 kW maximum in cold weather operation
- -25 to +110° F operating temperature range with cold weather kit
- -28 to +160° F storage temperature range
- Separate cold weather kit
 - Reusable box
 - Hose heating blankets
 - Circulation blower
 - 3,000 gallon tank immersion heater
 - Floor insulating mats
 - Hanging door strips



Engineered Solutions LLC

2740 South Highway 1651
 Stearns, KY 42647-6209
 606-376-5021 www.outdoorventure.com